

5 SUPPORT CONNECTION DETAIL

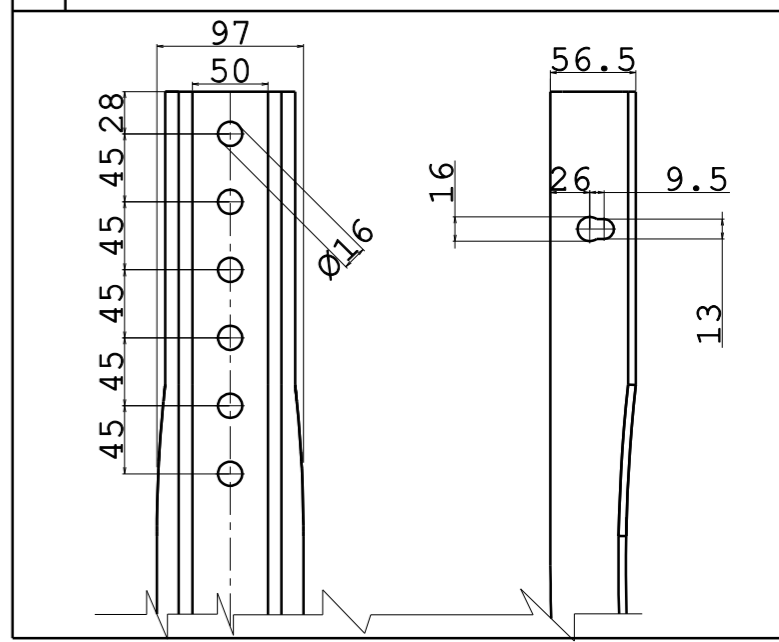

Tank composition

Pos.	Denomination	Q.ty
1	FILLING CAP	1
2	LEVEL INDICATOR VDO TYPE CONNECTION	1
3	DIESEL DRAINAGE	1
5	SUPPORT 44/54	2
6	STRAP	2
7	GROUND CONNECTION	1

MARK DETAIL



Tank dimension	0	EMISSION	27/06/2016	MM	FM	EB
	Rev.	Modify description	Date	Dis.	Ver.	App.
Full capacity 102 Lt	Part name :	Diesel oil tank 100 LT Al/Steel/Stainl.steel fam. 440x540				
Support weight 16 Kg	Part code :	NSG (X) 0100050C100	Replace the	Material code		
Tank weight (F,I,T) kg (A) kg	Scale	1:10	Replaced by	(X)=F:Steel DC03A EN 10130	General tolerances: ISO 2768 V	
Dimensions 500x440x540 mm				(X)=I:Stainless steel AISI 304 UNI EN 10088		
				(X)=T:Text stain.steel AISI 304 UNI EN 10088	Drawing format A3	
				(X)=A:Aluminium EN AW 5754	DO NOT MAKE MEASUREMENTS ON DRAWING DO NOT CHANGE WITHOUT TECHNICAL OFFICE AUTHORIZATION	

